



ING YU PRECISION INDUSTRIES CO., LTD.

43-11, Sha-Tien Rd. Sha-Lu, Taichung Hsien, **TAIWAN** 433
TEL: +886-4-26358569 FAX: +886-4-26353068
E-mail: info@ingyu.com

Superior Stamping Technologies
PO Box 402, Ridgefield, New Jersey, **USA** 07657
TEL: 1-201-945-5874
FAX: 1-201-945-6498
E-mail: info@sstamericas.com

Ing Yu International LLC
Rm. 1601, No 1, Lane 3, Biquan Rd.
Minhang, Shanghai, **CHINA** 201100
TEL: 86-21-64128827
FAX: 86-21-64125200
E-mail: ingy@sh163.net

MAWI GmbH
Beermiss 18, D-75323 Bad Wildbad-Calmbach **GERMANY**
TEL: +49-7081-95444-16
FAX: +49-7081-95444-10
E-mail: peter.kaiser@mawi-gmbh.de

UNITECH MetalStamping Technologies Pvt, Ltd.
5, Elphinstone Road, Camp, Pune, **INDIA** 411001
Tel: +91-20-26334381
Fax: +91-20-26334383
E-mail: peter@unitechmetalstamp.com

More than a Press producer, ING YU is devoted to creating the value for Customers.

Originality

Apex • Crank series
• Knuckle series

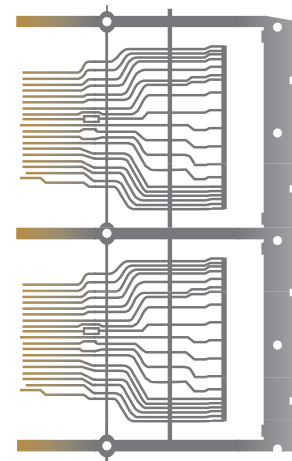
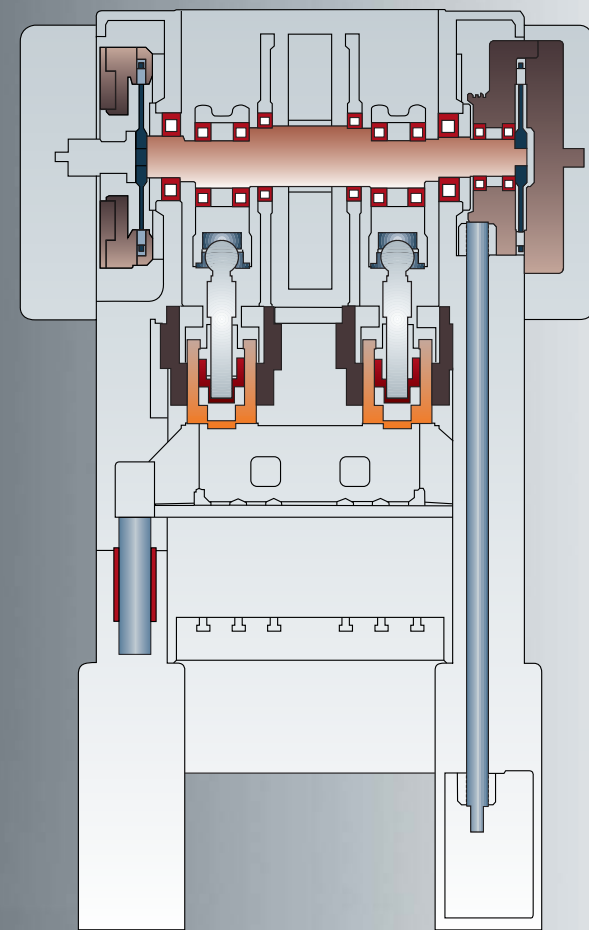

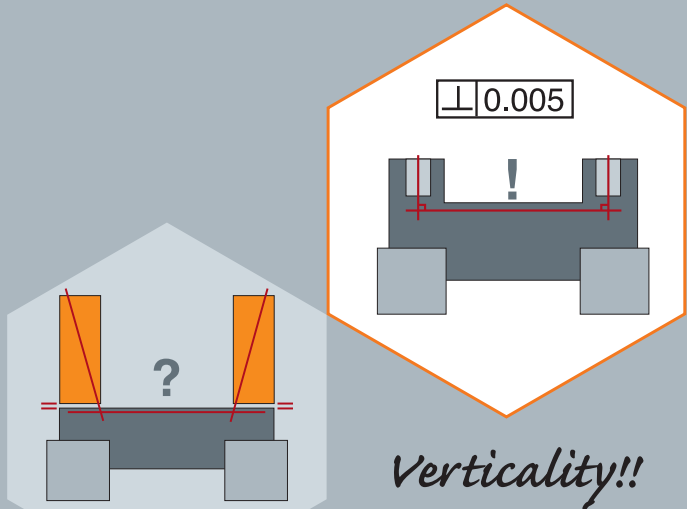
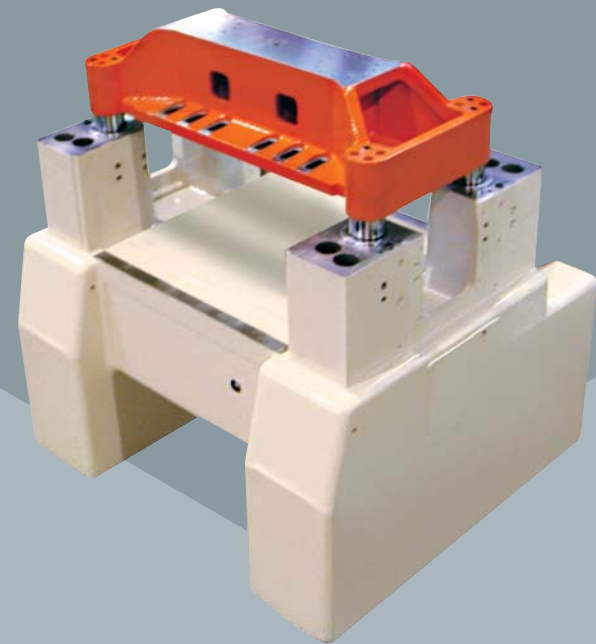

Verticality!!

Hydra. Static

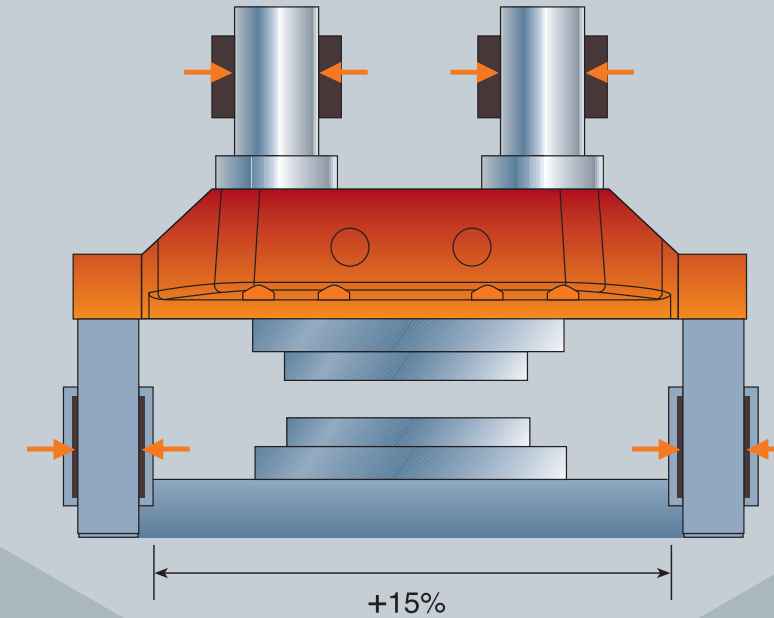

Balance & Torque.....

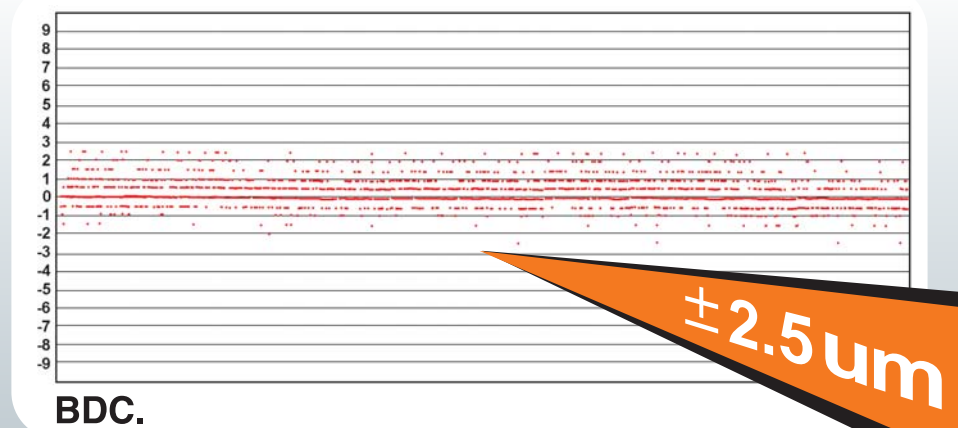
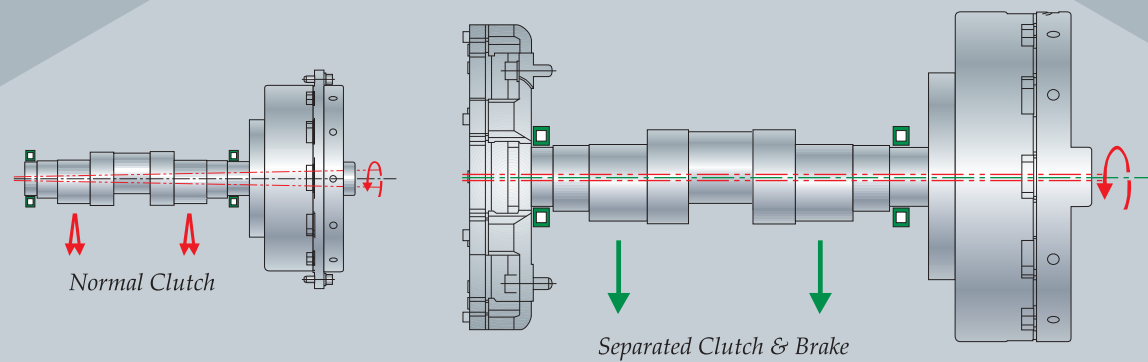

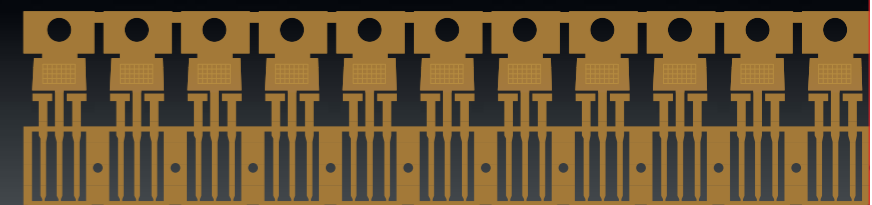
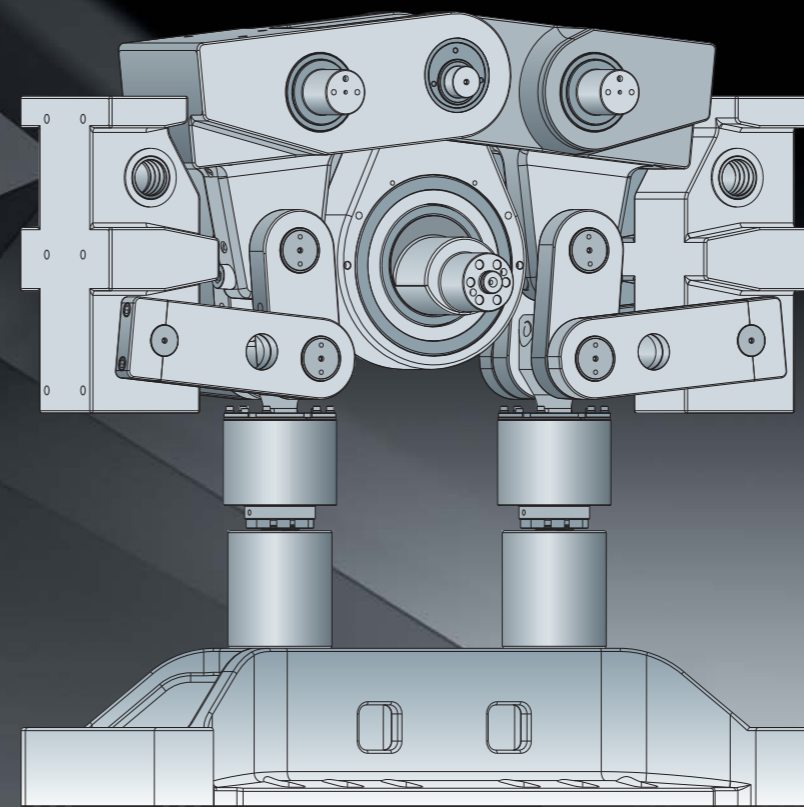

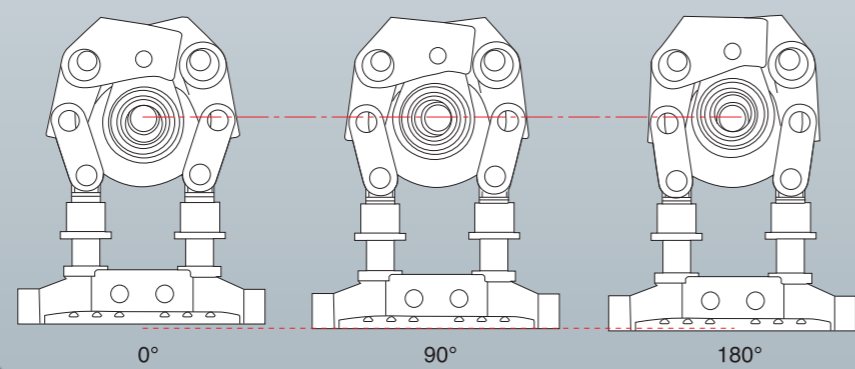
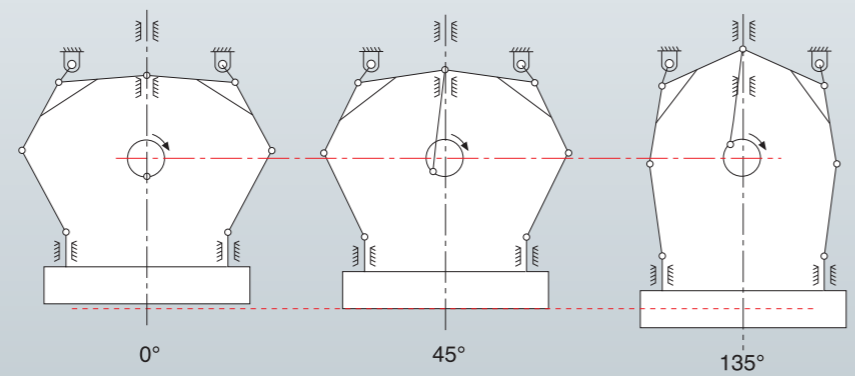
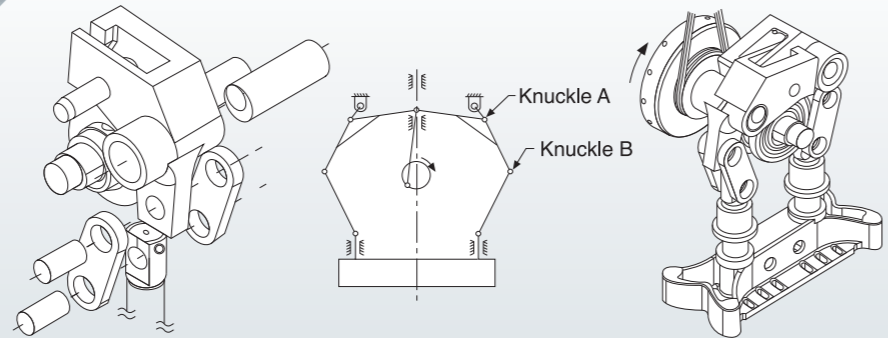

Knuckle-Link by compressive direction
 US, German, Japan, Korea, Taiwan, China patent protected

Knuckle vs Crank slide movement

- Eccentric load's deformation is 1/3 of crank type.
- Total clearance is under 50% of JIS special grade.
- Above 1mm to BDC period is double of crank type.

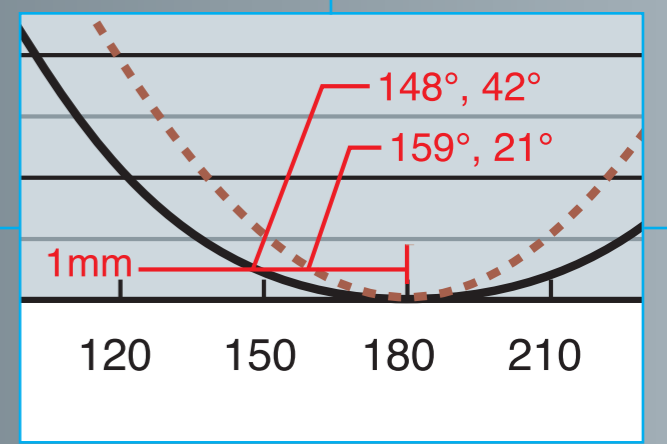
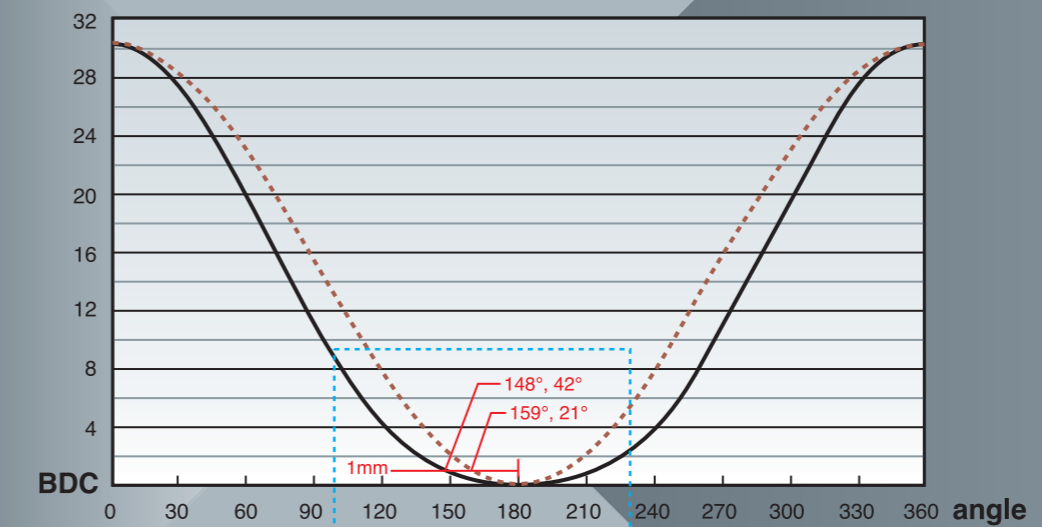

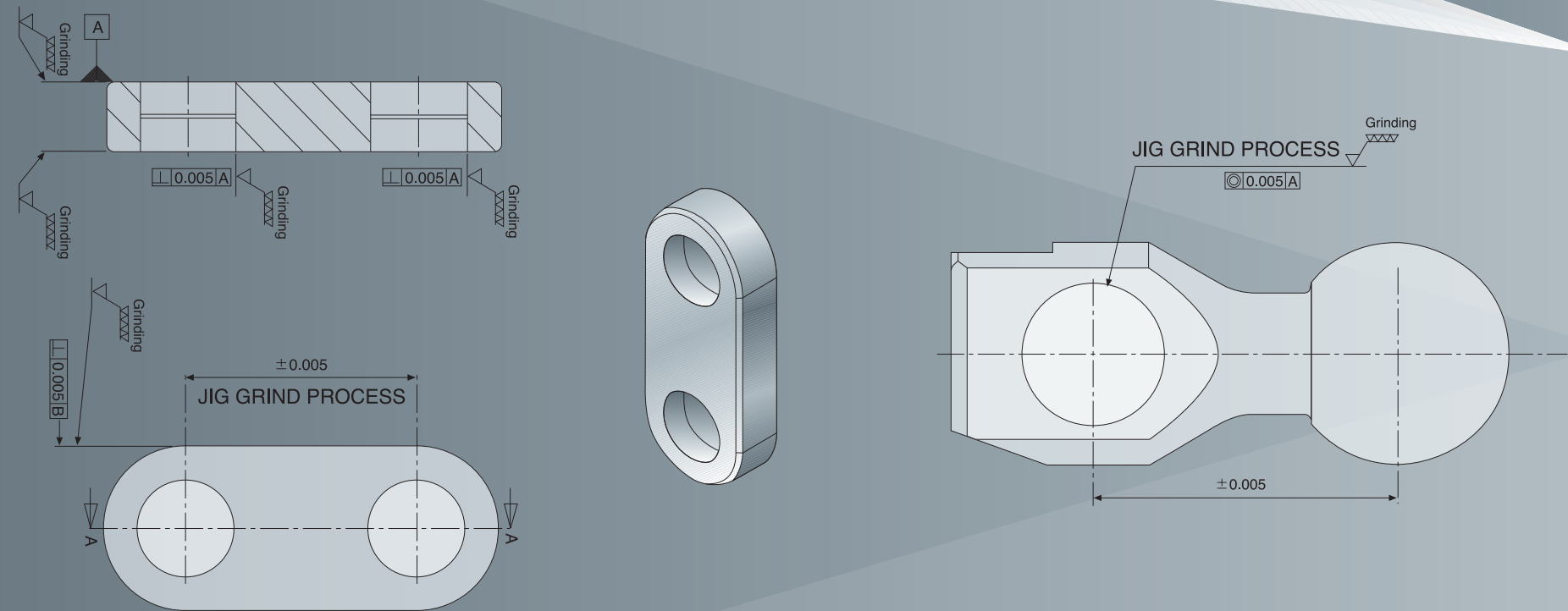

Synchronization and Multi-clearance

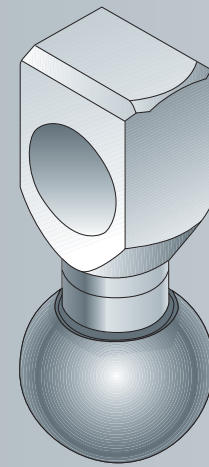

Inner annealing, heat treatment and sub-zero treatment

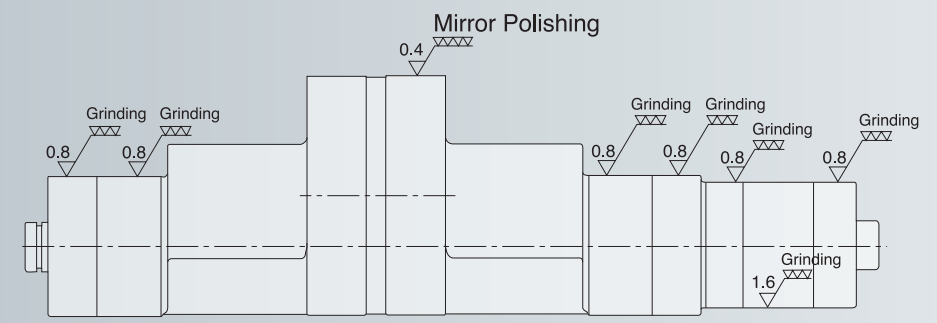

Bi-Metal Coating Process

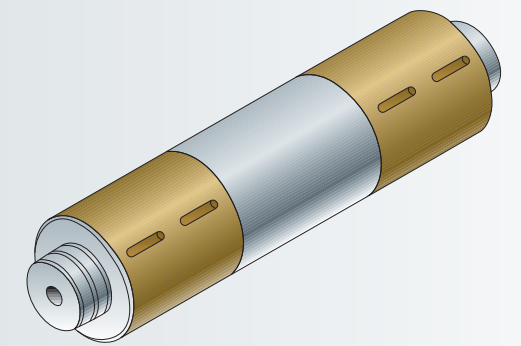

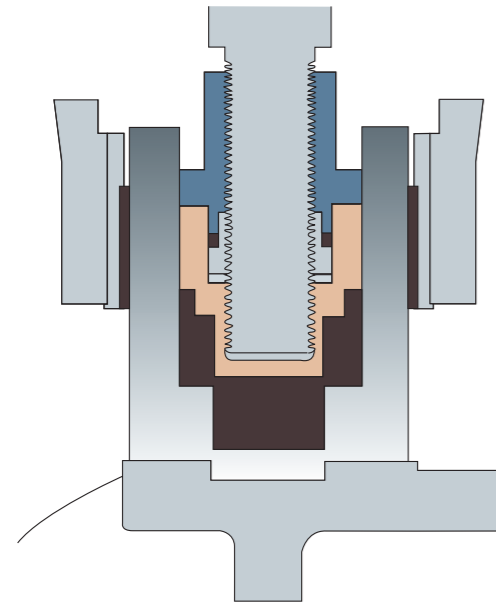

Slide Quick Lift (optional)

The height of slide quick lift is 50 mm at Apex-crank and 70 mm at Apex-knuckle. It helps users to solve the problem occurred on tooling easily, including material sticking, tool jamming, scrap, and punch changing.

After trouble shooting, the slide returns to its original height quickly and B.D.C. is kept still without re-adjust checking and saving much time.

Moreover, users could select a shorter stroke without any inconvenience caused by tool operation and inspection. The shorter stroke can improve verticality of reciprocation, prolong tool life and increase productivity.



Thermo-static inverter cooling

Warm up the press by thermo-static system around 1 hour before running the production. At the first 3 hours of running, the oil temp. deviation is only 4°C, then keep still at $\pm 0.5^\circ\text{C}$.

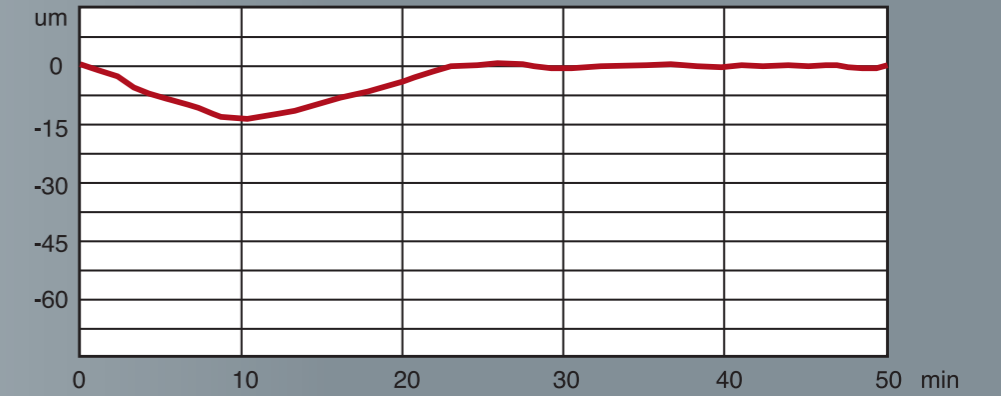

B.D.C at start running period with thermo-static system

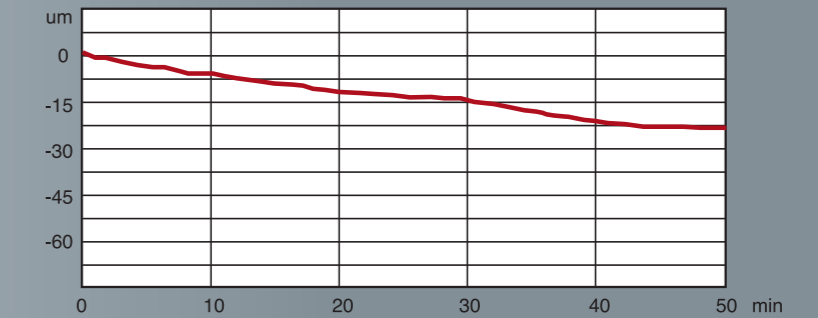

B.D.C at start running period with normal cooling



Basic PLC control :

Colorful HMI screen is applied to display press situation friendly by colors, schematic and letters.

100 sets of tooling memory including die-height, running speed, pitch, detector setting and etc, it can auto-adjust device's position and parameter command to save much time and eliminate manual mis-adjustments while mounting tools and modify settings.

Temp, air/oil pressure, running current, tooling running hours are displayed without searching relative gauges. All situations, operations and messages are recorded to shorten trouble shooting time by tracing past history.

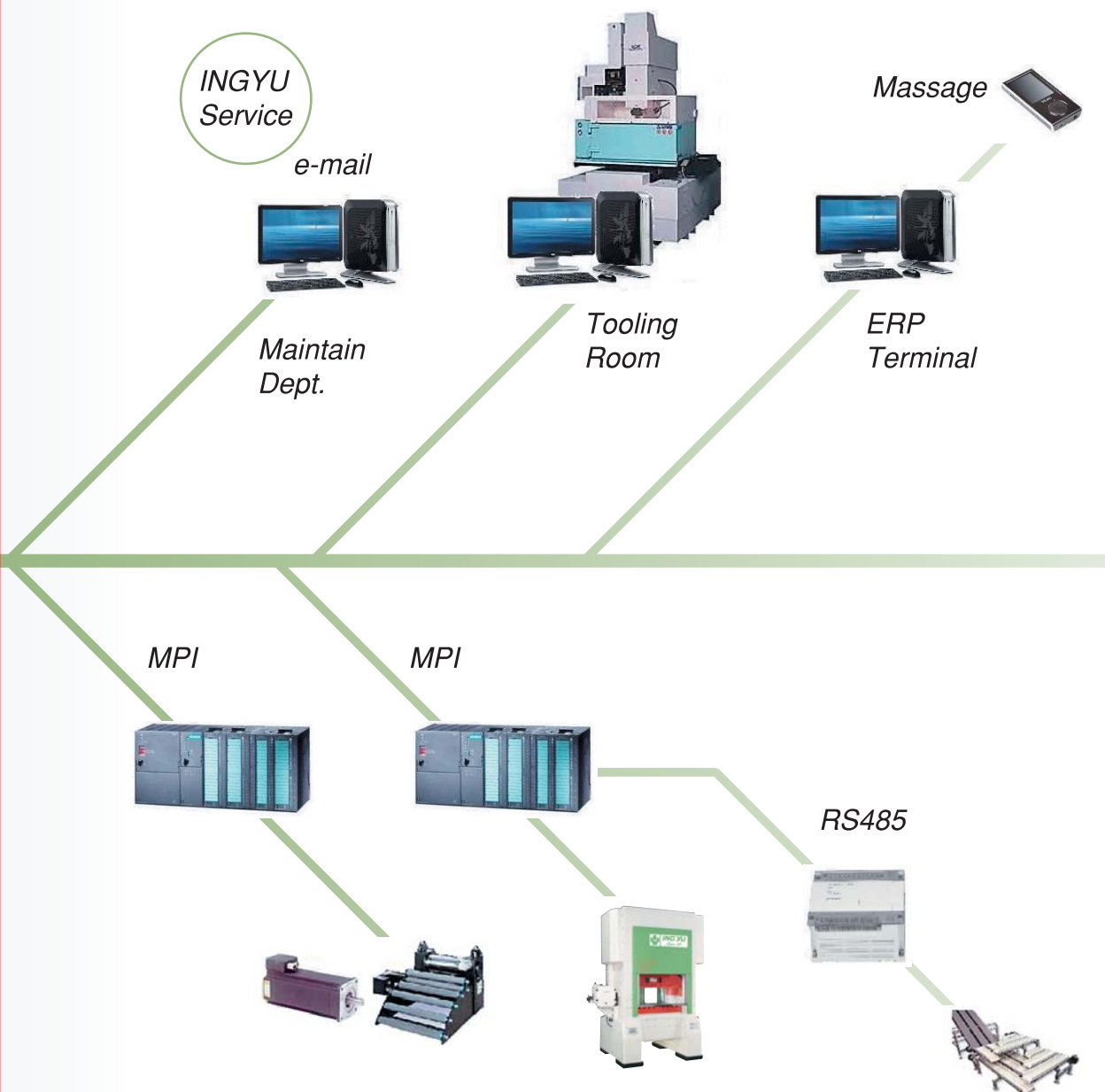

Automation application with multiple equipments :

Users could operate and command at centralized workstation to multiple equipments of whole production line, including servo drive, detect device, transfer-robot and etc.

Of course, the situation of remote equipments is transferring back and showing at workstation. The system memory could open a shared area for remote equipments' parameters and settings.

Job dispatch application by Ethernet :

System could transfer the production information to PC at manager office. The information is compatible with ERP system to reduce manual input job.

The tooling running information helps tooling manage dept. for remote-monitoring. The equipments' running and error information helps maintenance dept. planning periodical maintain schedule and trouble shooting.

Of course, ERP system could dispatch the job order and showing at workstation, tooling dept. could transfer new tooling setting, maintenance dept. could remote-tuning the equipments' parameter.

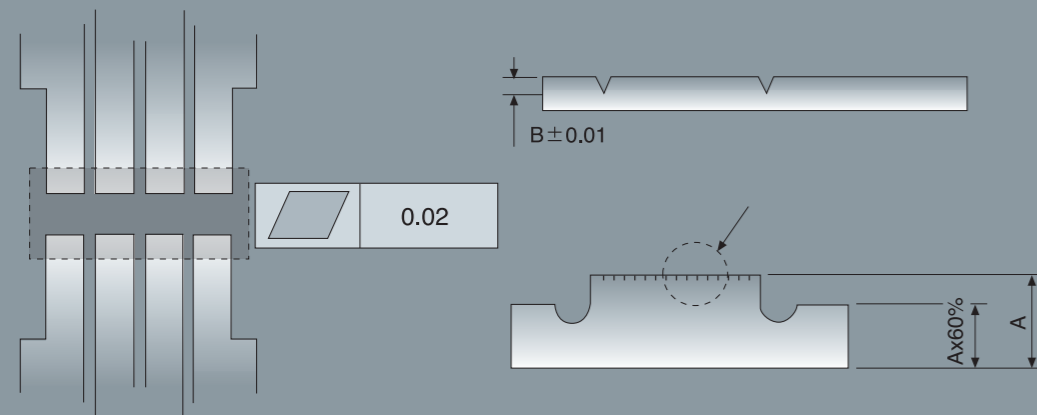

Precise stamping application :

- Ultra high speed stamping above 1,000spm
- Precise flatness control
- Forging thickness control
- High BDC reciprocation
- Micro stamping

Standard Accessories

- Slide adjust motor(0.01mm)
- Front & rear safety guard
- Joint for air gun x 1
- Mis-feed circuit x 3
- Material-end circuit x 1
- Batch/Cam circuit x 5
- Inverter motor
- Centralized workstation system
- Anti-vibration air type cushion (Apex 30-60)
- Anti-vibration spring type cushion (Apex-Knuckle)
- Die Arm (Apex60 above)
- Die Lifter (Apex-Knuckle)

Optional Accessories

- Slide quick lift
- Gripper Feed
- Gear Change Roll Feed
- Straightener + S-Loop (Lamination)
- Dual Head Coiler (Lamination)

Feeding accessory



High Speed Feeder	Gripper type		Gear change type				
Type	FGP-806		FDG-12		FDG-30		FDG-40
Max width (mm)	80		120		300		400
Max thickness (mm)	2.0		2.3		2.3		2.3
Max pitch (mm)	0-60		4-120	12-360	4-120	12-360	4-120 12-360
Max speed (m/min)	40		60		60		60

Dual Head Uncoiler				Straightener with S Loop			
Type	DCT-12	DCT-30	DCT-40	Type	FRS-12	FRS-30	FRS-40
Max outside dia (mm)	800	1200	1200	Max width (mm)	120	300	400
Valid inside dia (mm)	450-520	450-520	450-520	Valid thickness (mm)	0.3-1.0	0.4-1.2	0.4-1.2
Max load per head (kg)	800	1000	1500	Max speed (m/min)	60	60	90
Hydraulic expand	yes	yes	yes	Drive motor (hp)	2	3	5

Machine Specification													
TYPE		Apex-30				Apex-45				Apex-60			
Capacity	tons	30				45				60			
Slide stroke	mm	10	20	30	40	10	20	30	40	20	30	40	50
Press speed	spm	200	200	200	200	200	200	200	200	200	200	200	200
		1400	1200	1000	800	1300	1100	900	700	1000	800	600	500
Shutheight	mm	255	250	245	240	285	280	275	270	325	320	315	310
Area of bolster	mm	600x450				800x550				1000x650			
Bolster thickness	mm	100				120				140			
Area of slide	mm	600x340				800x400				1000x450			
Shutheight adjustment	mm	40				50				50			
Main motor	hp	15				15				20			
Dimension of Press													
Height of Press (A)	mm	2270				2510				2810			
Height for Operation (B)	mm	800				850				950			
Height for Scrap out (C)	mm	330				310				290			
Width of Press (D)	mm	1150				1350				1650			
Depth of Press (F)	mm	1100				1200				1400			
Height of feed line(G)	mm	100 ± 20				115 ± 20				135 ± 20			
Width of Upright opening(H)	mm	220				260				300			
Net Weight	tons	5				8				12			

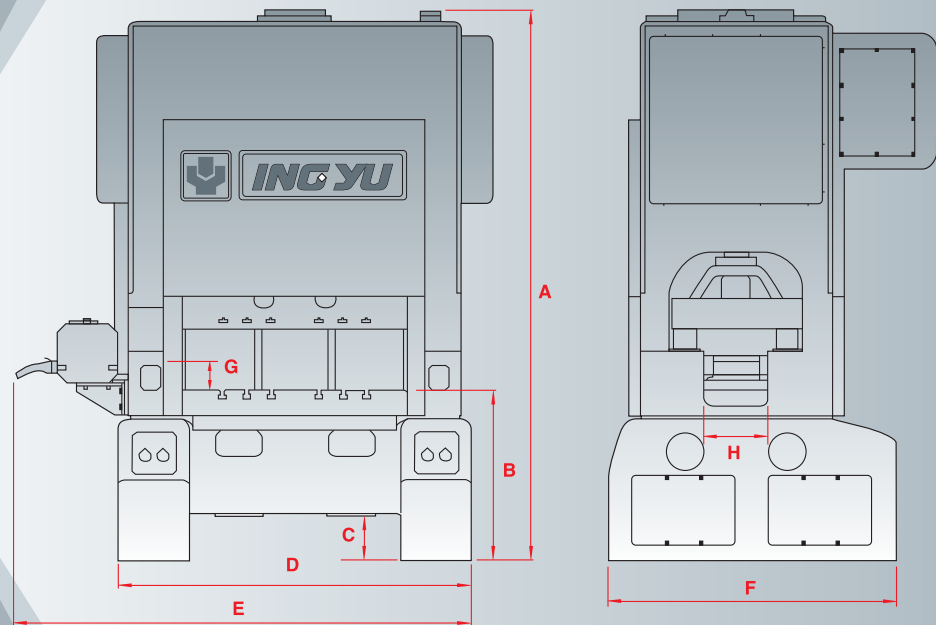

We reserve the right to modify all data contained in this catalogue without notice.(Please contact with us for detail specification & dimension of the press.)

Machine Specification													
TYPE		Apex-K VIII				Apex-K XII				Apex-K XIII			
Capacity	tons	80				125				160			
Slide stroke	mm	20	30	40	50	20	30	40	50	20	30	40	50
Press speed	spm	200	200	200	200	200	200	200	200	200	200	200	200
		700	600	500	500	700	600	500	500	600	500	400	400
Shutheight	mm	365	360	355	350	385	380	375	370	385	380	375	370
Area of bolster	mm	1200x750				1400x850				1700x850			
Bolster thickness	mm	140				160				160			
Area of slide	mm	1200x500				1400x640				1700x640			
Shutheight adjustment	mm	50				50				50			
Main motor	hp	30				30				40			
Dimension of Press													
Height of Press (A)	mm	3600				3800				4300			
Height for Operation (B)	mm	1010				1060				1080			
Height for Scrap out (C)	mm	300				280				130			
Width of Press (D)	mm	1930				2200				2600			
Depth of Press (F)	mm	1600				1800				2000			
Height of feed line(G)	mm	155 ± 20				165 ± 20				165 ± 20			
Width of Upright opening(H)	mm	350				400				450			
Net Weight	tons	18				25				32			

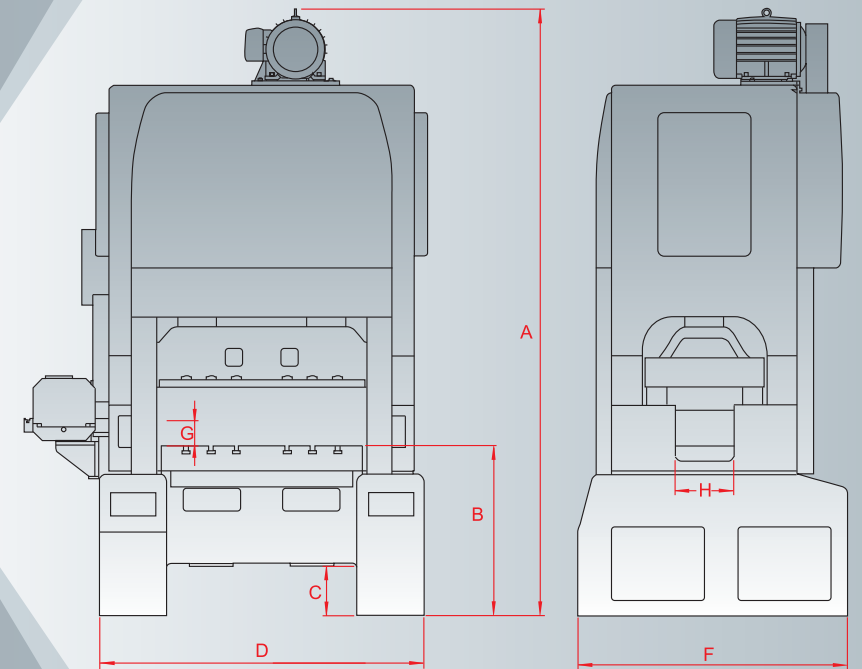

We reserve the right to modify all data contained in this catalogue without notice.(Please contact with us for detail specification & dimension of the press.)

